



DGL

Product Information Sheet

Standard Specification

Dimensions

Width/Depth/ (mm)	1180/1180
Filling inlet diameter (mm)	350
Outlet diameter (mm)	50
Tare weight (kg)	See below
Capacity (L)	See below

Composition

Liner	LMDPE ¹
Framework with anti-tilt bars	Mild Steel (galvanised)
Screw cap lid / Seal	HDPE ⁴ / EPDM ²
Outlet / Seal	UPVC ³ / EPDM ²

Options

460 mm clamp band lid, 460 mm arag lid
 Various valves / seals, including viton
 75mm outlet
 Fusion welded HDPE⁴ flanged outlets are available for connecting stainless steel butterfly valves
 Full fork tunnels on frame (maximum handling stability)
 Venting / anti-vac / pressure relief
 Vinyl logos
 Trem card holders
 Coloured liner
 Anti-static liner

1 – Linear Medium Density Polyethylene 4 – High Density Polyethylene
 2 – Ethylene Propylene Diene Monomer (rubber compound)
 3 – Unplasticised Polyvinyl Chloride

Description

The DGL is a reusable IBC designed for the transportation and storage of viscous liquids.

The DGL liner is rotationally moulded in natural coloured UV stabilised linear medium density polyethylene. The polymer provides strong resistance to industrial wear and tear. The liner has a conical base to enable total draining of the contents. It is supported and protected by a galvanised mild steel frame providing excellent resistance to the elements. The units are interstackable for loading and space saving and have integral four way fork truck entry with anti-tilts to improve handling efficiency.

The liner inlet is a 350mm HDPE⁴ screw cap fitted with an EPDM² O-ring seal. The outlet is a 50mm fusion welded socket to a single union UPVC³ ball valve fitted with EPDM² seals. It is attached to the liner via a fusion welded 50mm BSP male threaded socket. A 50mm BSP female threaded end on each side of the valve terminates in a 50mm male camlock adaptor and dustcap. The dustcap acts as a secondary closure and is attached to the outlet via a cable.



- A multi-trip composite IBC for the transportation and storage of liquids
- Particularly suitable for high viscosity fluids
- 4 way fork lift truck entry
- Designed for stability in storage and transport
- 50 and 75 mm flanged outlet options

Continued overleaf

DGL Product Range

Type	Volume litres	Dimensions Width/Length/Height mm	Weight Kg
DGL 500	500	1180 / 1180 / 1525	116
DGL 750	750	1180 / 1180 / 1724	124
DGL 1000	1000	1180 / 1180 / 1850	130
DGL 1250	1250	1180 / 1180 / 2109	151
DGL 1500	1500	1180 / 1180 / 2338	190
DGL 1750	1750	1180 / 1180 / 2521	197
DGL 2000	2000	1180 / 1180 / 2754	212
DGL 2250	2250	1180 / 1180 / 3008	240

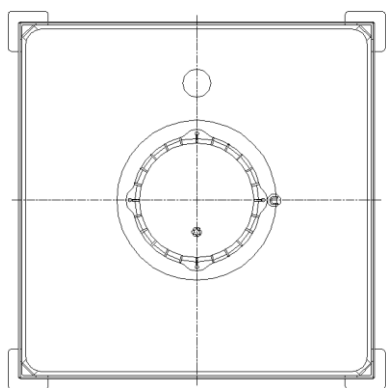

Plan view

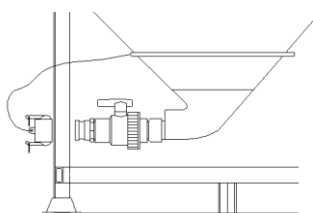

Outlet

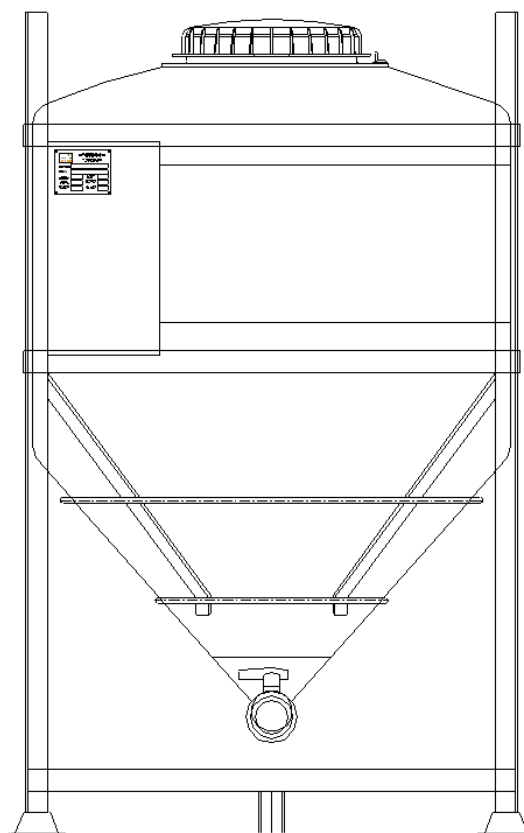

Side elevation

Whilst every attempt has been made to ensure that the information provided in this product information sheet is accurate and reliable Francis Ward Limited cannot accept responsibility for the interpretation of the information provided

It is the responsibility of the user to determine the chemical compatibility of the container with its intended contents..



Francis Ward Limited

Brook House, 221 Bowling Back Lane, Bradford, BD4 8SJ, UK

Tel: +44 (0)1274 707030 Fax: +44 (0)1274 724704

Email: sales@francisward.com

Website: www.francisward.com