



Container shown is a PCM Mild Steel lined 1000L in green paint finish, with FSAF Safety Air Feed connected.

- A multi-trip lined steel IBC designed for pressurised discharge of contents
- 4 way fork lift truck entry with anti-tilt facility
- 2 way pallet truck entry
- Top/crane lift facility option
- UN Group II approved

PCM Mild Steel Lined

Product Information Sheet

Standard Specification

Dimensions

Width/Depth/Height (mm)	1200/1200/
Filling inlet diameter (mm)	460
Outlet diameter (mm)	50
Tare weight (kg)	See product range
Capacity Nominal (L)	See product range

Composition

Tank body	Mild Steel
Tank lining	LLDPE ¹ / Rubber
Framework	Mild Steel
Inlet / Seal	HDPE ² / EPDM ³
Outlet / Seal	HDPE ² / EPDM ³

Maximum Working Pressure

BAR / PSI	1.36 / 20
-----------	-----------

UN Certification

Group II approved	Y2.6
-------------------	------

Options

Paint colour options for body and pallet base

Outlet valve seal types including Viton

1 – Linear Low Density Polyethylene

2 – High Density Polyethylene

3 – Ethylene Propylene Diene Monomer (rubber compound)

Description

The PCM mild steel lined is a reusable IBC designed for the transportation, storage and pressure discharge of hazardous liquids.

The pressure discharge method is highly cost effective; containers are not left with customers. Instead a unit on average can achieve 3 deliveries a week. The container also comes with a "Safety Air Feed". This enables delivery personnel to discharge the IBC quickly and effectively, whilst safely standing on the ground. The cylindrical tank body, manufactured from mild steel, is inherently much stronger than square tanks and with no crevices is easy to clean down. The container can be lined inside with an anti-corrosion lining of LLDPE or rubber. The tank body can be painted with 2 pack promastic paint or hot dip galvanised to provide resistance to the external environment. The pallet is detachable and replaceable. It connects with the top design so units can be stacked for loading and space saving. It can also be painted with 2 pack promastic paint or galvanised to provide excellent resistance to the elements. It has four way fork truck entry with anti-tilts and a two way pallet truck entry to improve handling efficiency.

The Tank inlet which is 460mm in diameter has a HDPE manway cover with a galvanised carrying strap, secured by 24 bolts. It is fitted with an EPDM seal and 2 x 38mm camlock and dustcaps. The outlet consists of a 50mm threaded outlet pipe in HDPE from the tank body to a 50mm GRPP⁴ lockable ball valve, fitted with EPDM seals and terminating in a 38mm integral camlock adapter complete with a dustcap. The dustcap is retained to the valve handle via a retaining cable.

PCM Mild Steel Lined Product Range

Type	Volume litres	Dimensions Width/Length/Height mm	Weight Kg
PCM 600	600	1200 / 1200 / 1410	290
PCM 1000	1000	1200 / 1200 / 1810	325

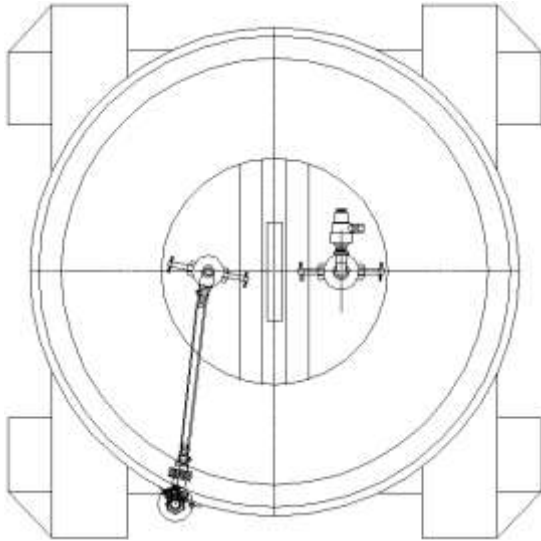

Plan View

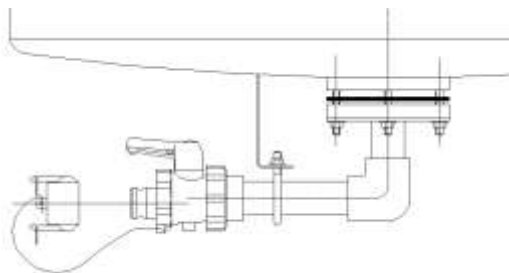

Outlet View

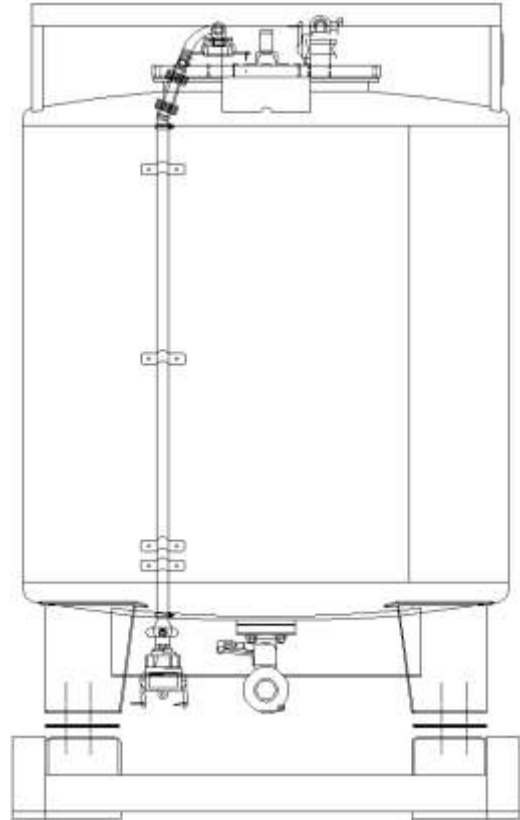

Front Elevation

Whilst every attempt has been made to ensure that the information provided in this product information sheet is accurate and reliable Francis Ward Limited cannot accept responsibility for the interpretation of the information provided

It is the responsibility of the user to determine the chemical compatibility of the container with its intended contents.



Francis Ward Limited

Brook House, 221 Bowling Back Lane, Bradford, BD4 8SJ, UK

Tel: +44 (0)1274 707030 Fax: +44 (0)1274 724704

Email: sales@francisward.com

Website: www.francisward.com