



DGC 90°

Product Information Sheet

Standard Specification

Dimensions

Width/Depth (mm)	1180/1180
Filling Inlet diameter (mm)	350
Outlet diameter (mm)	200
Tare Weight (kg)	See product range
Capacity (L)	See product range

Composition

Liner	LMDPE ¹
Framework with Anti-tilt bars	Mild Steel (galvanised)
Inlet / Seal	GRPP ² / EPDM ³
Outlet / Seal	Various (see options)

Options

- 460 mm clamp band lid, 460 mm arag lid
- Valve outlet options including Mucon and Slide
- Full fork tunnels on frame (maximum handling stability)
- Venting / anti-vac / pressure relief
- Vinyl logos
- Trem card holders
- Complete open top version
- Coloured liner
- Anti-static liner

1 – Linear Medium Density Polyethylene

2 – Glass Reinforced Polypropylene

3 – Ethylene Propylene Diene Monomer (rubber compound)

Description

The DGC 90° is a re-usable silo IBC designed for the transportation and storage of dry goods e.g. powders and granules.

The DGC 90° liner is a one piece rotational moulding made from natural coloured UV stabilised linear medium density polyethylene. It has a 90° conical form and is supported and protected by a galvanised mild steel frame. The base of the frame has an integral four way fork truck entry.

The liner inlet which is 350mm in diameter has a GRPP screw cap fitted with an EPDM O-ring seal. The vertical outlet at the base of the liner can be specified with a variety of valves to suit individual applications.

Continued overleaf



Container shown is a DGC 750-90° fitted with a 14" screw lid and an 8" slide valve

- A multi-trip silo IBC for the transportation and storage of dry goods
- 4 way fork lift truck entry
- Designed for stability in storage and transport
- Range of outlet options

DGC 90° Product Range

Type	Volume litres	Dimensions Width/Length/Height mm	Weight Kg
DGC 500-90°	500	1180 / 1180 / 1465	100
DGC 750-90°	750	1180 / 1180 / 1685	110
DGC 1000-90°	1000	1180 / 1180 / 1825	120
DGC 1250-90°	1250	1180 / 1180 / 2045	125
DGC 1500-90°	1500	1180 / 1180 / 2270	140
DGC 1750-90°	1750	1180 / 1180 / 2455	150
DGC 2000-90°	2000	1180 / 1180 / 2715	165
DGC 2250-90°	2250	1180 / 1180 / 2940	175

Plan view

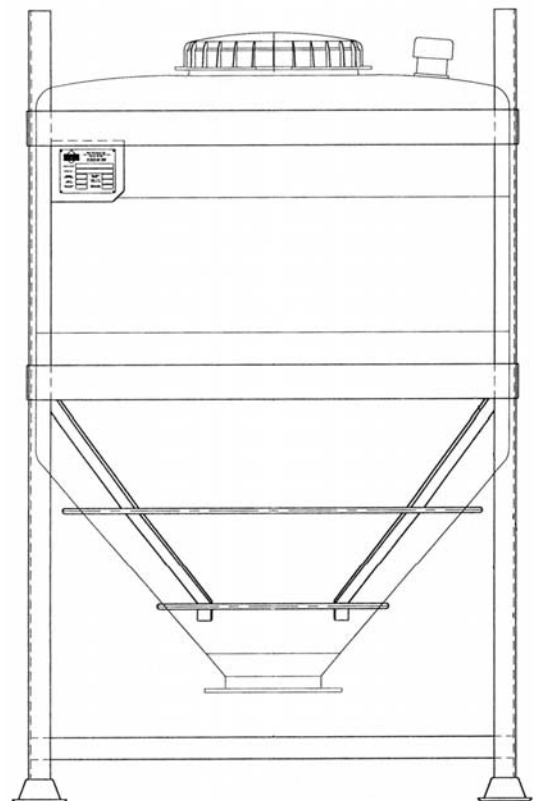
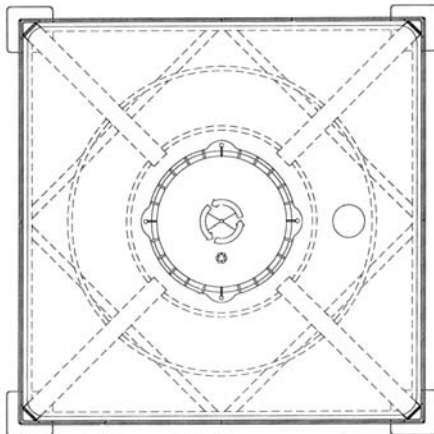

Side Elevation

Whilst every attempt has been made to ensure that the information provided in this product information sheet is accurate and reliable Francis Ward Limited cannot accept responsibility for the interpretation of the information provided.

It is the responsibility of the user to determine the chemical compatibility of the container with its intended contents.



Francis Ward Limited

Brook House, 221 Bowling Back Lane, Bradford, BD4 8SJ, UK

Tel: +44 (0)1274 707030 Fax: +44 (0)1274 724704

Email: sales@francisward.com

Website: www.francisward.com