



# DGO 120°

## Product Information Sheet

### Standard Specification

#### Dimensions

Width/Depth (mm)	1180/1180
Filling inlet diameter (mm)	350
Outlet diameter (mm)	200
Tare weight (kg)	See product range
Nominal capacity (L)	See product range

#### Composition

Liner	LMDPE <sup>1</sup>
Framework with anti-tilt bars	Mild Steel (galvanised)
Inlet / Seal	HDPE <sup>2</sup> / SR <sup>3</sup>
Outlet / Seal	Various (see options)

#### Options

- 460 mm clamp band lid, 460 mm arag lid
- Valve outlet options including Mucon and Slide
- Full fork tunnels on frame (maximum handling stability)
- Venting / anti-vac / pressure relief
- Vinyl logos
- Trem card holders
- Complete open top version
- Coloured liner
- Anti-static liner

- 1 – Linear Medium Density Polyethylene
- 2 – High Density Polyethylene
- 3 – Silicone Rubber

#### Description

The DGO 120° is a reusable silo IBC designed for the transportation and storage of dry goods e.g. powders and granules.

The DGO has an open top removable lid. The open top allows for ease of entry / filling and monitoring of dry goods.

The DGO liner is rotationally moulded in natural UV stabilised linear medium density polyethylene. The polymer has strong resistance to industrial wear and tear. The 120° conical base is designed to provide total discharge of the contents. The liner is supported and protected by a galvanised mild steel frame, providing excellent resistance to the elements. The base of the frame has integral four way fork truck entry with anti-tilts to improve handling efficiency and is stackable.

The liner inlet which is 350mm in diameter has a HDPE<sup>2</sup> screw cap fitted with an SR<sup>3</sup> O-ring seal as standard. The vertical outlet at the base of the frame can be specified with a variety of valves to suit individual applications.



Container shown is a DGO 1000 - 120° fitted with a removable open top lid, galvanised frame and a 10° slide valve, without anti tilts.

- A multi-trip silo IBC for the transportation and storage of dry goods
- Open top 'drop on' removable lid
- 120° cone angle; ideal for most powder applications
- 4 way fork lift truck entry
- Designed for stability in storage and transport

## DGC 90° Product Range

Type	Volume litres	Dimensions Width/Length/Height mm	Weight Kg
DGO 500-120°	500	1180 / 1180 / 1465	100
DGO 750-120°	750	1180 / 1180 / 1656	110
DGO 1000-120°	1000	1180 / 1180 / 1782	120
DGO 1250-120°	1250	1180 / 1180 / 2045	125
DGO 1500-120°	1500	1180 / 1180 / 2270	140
DGO 1750-120°	1750	1180 / 1180 / 2454	150
DGO 2000-120°	2000	1180 / 1180 / 2715	165
DGO 2250-120°	2250	1180 / 1180 / 2940	175

Plan view

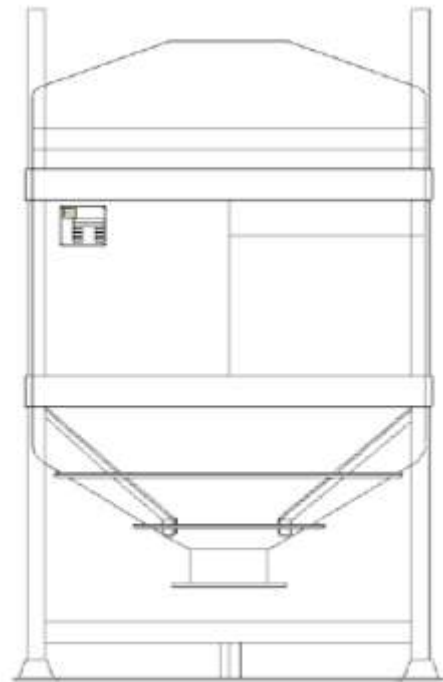
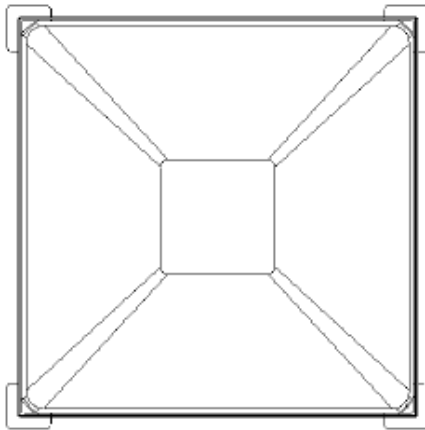

Side elevation

Whilst every attempt has been made to ensure that the information provided in this product information sheet is accurate and reliable Francis Ward Limited cannot accept responsibility for the interpretation of the information provided.

It is the responsibility of the user to determine the chemical compatibility of the container with its intended contents.



Francis Ward Limited

Brook House, 221 Bowling Back Lane, Bradford, BD4 8SJ, UK

Tel: +44 (0)1274 707030 Fax: +44 (0)1274 724704

Email: [sales@francisward.com](mailto:sales@francisward.com)  
 Website: [www.francisward.com](http://www.francisward.com)