



DGO 120

Product Information Sheet

Standard Specification

Dimensions

Width/Depth/ (mm)	1180/1180
Height	See table overleaf
Inlet diameter (mm)	350
Outlet diameter (mm)	250
Tare weight (kg)	See table overleaf
Capacity (L)	See table overleaf

Composition

Liner	LMDPE ¹
Frame	Mild Steel (galvanised)

Options

- Iris or slide valve
- Full fork tunnels on frame (maximum handling stability)
- Vinyl logos
- Trem card holders
- Coloured liner
- Anti-static liner

1 – Linear Medium Density Polyethylene

Description

The DGO 120° is a reusable silo IBC designed for the transportation and storage of dry goods e.g. powders and granules.

The DGO has an open top with a removable lid. The open top allows for ease of entry / filling and monitoring levels of dry goods as well as cleaning.

The DGO liner is rotationally moulded in natural UV stabilised linear medium density polyethylene. The polymer has strong resistance to industrial wear and tear. The 120° conical base is designed to provide total discharge of the contents. The liner is supported and protected by a galvanised mild steel frame, providing excellent resistance to the elements. The base of the frame has integral four way fork truck entry with anti-tilts to improve handling efficiency and is stackable.

The vertical outlet at the base of the liner can be specified with a variety of valves to suit individual applications.



A reusable silo IBC for the transportation and storage of dry goods

Model shown is a DGO 120 fitted with a coloured bottle and slide valve.



DGO 120 Product Range

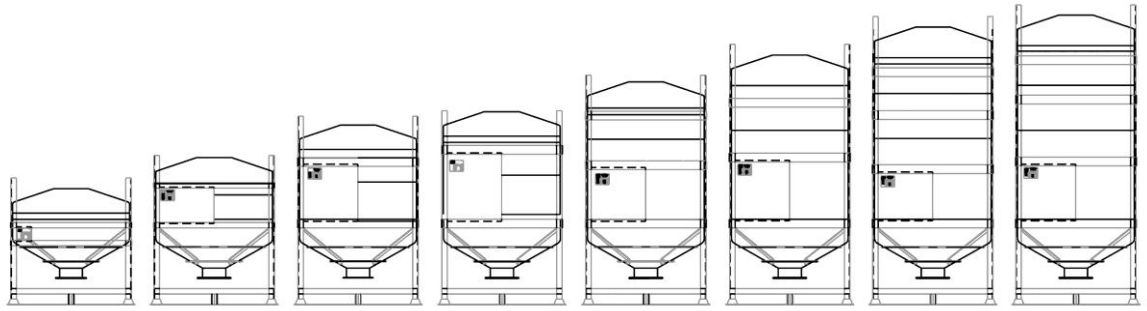

TYPE	500	750	1000	1250	1500	1750	2000	2250
Capacity - L	500 L	750 L	1000 L	1250 L	1500 L	1750 L	2000 L	2250 L
Height - mm	1150	1370	1730	1870	2105	2327	2526	2739
Tare Weight - kg	100	110	120	125	140	150	165	175

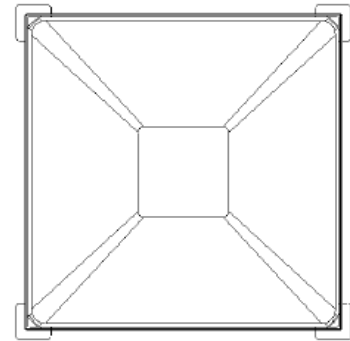

DGO 120 Plan View

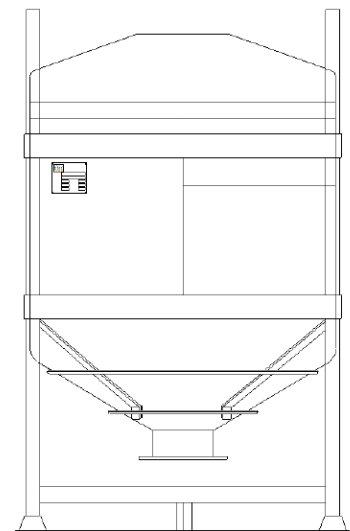

DGO 120 Front View

Whilst every attempt has been made to ensure that the information provided in this product information sheet is accurate and reliable Francis Ward cannot accept responsibility for the interpretation of the information provided. It is the responsibility of the user to determine the chemical compatibility of the container with its intended contents.



Francis Ward – A Division of The Rotational Mouldings Group

Brook House, 221 Bowling Back Lane, Bradford, BD4 8SJ, UK

Tel: +44 (0)1274 707030 | Fax: +44 (0)1274 724704 | Email: sales@francisward.com | Web: www.francisward.com